

**Installation Instructions:  
 For 12 VDC, Hydraulic Power Unit, Dual Double-Acting  
 (Two Independent Power UP / Power DOWN Circuits)**

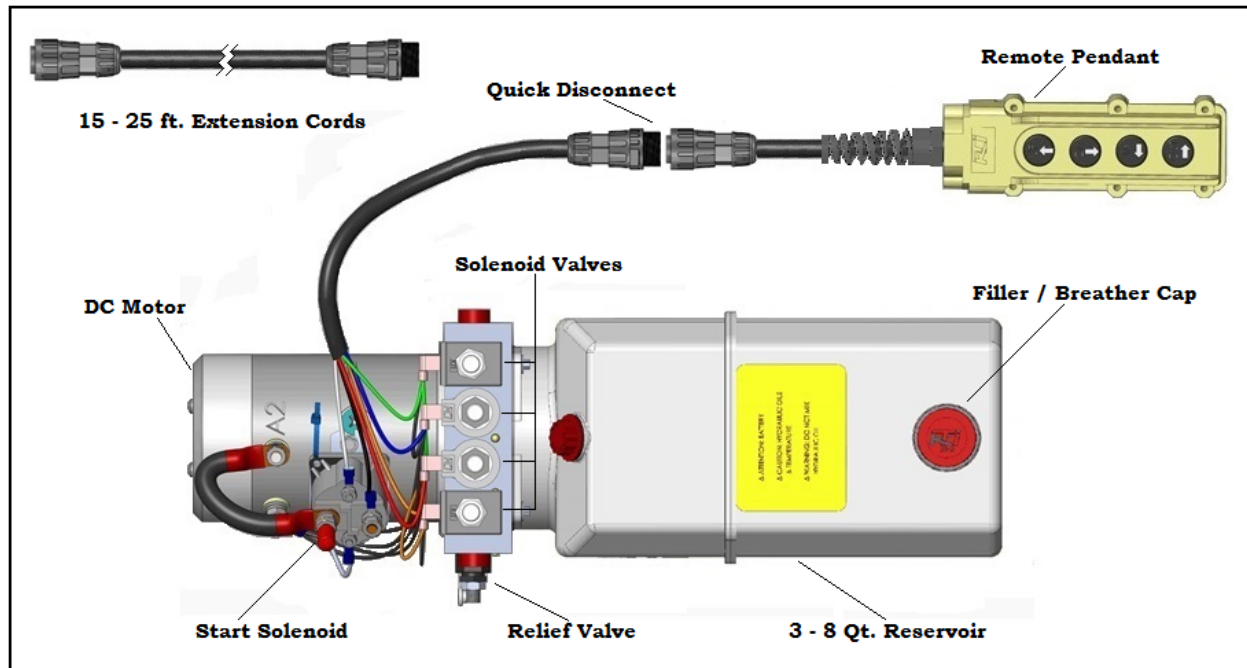

**Diagram A-1**

1. When stowing your three piece remote pendant, it is recommended that you store the remote switch box portion in your vehicle. This will help preserve the new condition of the remote control and prevent theft.
2. Remove the four-button pendant from the power unit at the quick disconnect.
3. Install 9/16-18 SAE ORB, SAE #6, hydraulic fittings into ports “A”, “B”, “A1 and “B1”. Torque fittings to 18 lb.-ft.
4. Mount the Power Unit using two, 3/8-16 x 3/4 mounting bolts (*Diagram A-2*).
5. Connect hydraulic hoses to two cylinders (applications may vary).
  - a. Connect the “A” port (UP function) hose to the **base** of the up and down function cylinder.
  - b. Connect the “B” port (DOWN function) hose to the **rod end** of the up and down function cylinder.
  - c. Connect the “A1” port (OUT function) hose to the **base** of the out and in function cylinder.
  - d. Connect the “B1” port (IN function) hose to the **rod end** of the out and in function cylinder.
6. Remove the Filler/Breather Cap and fill the reservoir with hydraulic approximately 1 inch from the top (**Please see fluid recommendations on page 2**).
7. Connect the battery **Ground** cable to the **Ground** terminal of the DC Motor (*Diagram A-2 & A-4*).
8. Connect the **Positive** cable from the battery to the start solenoid (*diagram A-5*). Please see *Battery Cable recommendation* (page 3) for proper cable length to use for your hydraulic power unit.
9. Use a wrench to hold the bottom nut in place, to torque the upper nut (to 3 ft.-lbs.) to fasten the battery connections.
10. Reconnect the four-button remote pendant at the quick disconnect.



11. UP/DOWN cylinder: Extend the cylinder by pressing the UP button while running the power unit keep an eye on the fluid level in the reservoir.
  - a. Insure that the fluid level doesn't go lower than ½ full during the initial start-up.
  - b. When the cylinder is fully extended, the reservoir should be about ½ full.
12. After the cylinder is fully extended, press the DOWN button to fully retract the cylinder.
 

**Please Note: When running your hydraulic power unit for the first time, do not allow the fluid to drop below the half full level, while raising or extending the hydraulic cylinder. This will cause the power unit to induce air into the system. During activation of the down function, the air in the system will cause aeration of the fluid and overflow the reservoir tank.**
13. IN/OUT cylinder: Extend the cylinder by pressing the OUT button while running the power unit keep an eye on the fluid level in the reservoir.
  - a. Insure that the fluid level doesn't go lower than ½ full during the initial start-up.
  - b. When the cylinder is fully extended, the reservoir should be about ½ full.
14. After the cylinder is fully extended, press the IN button to fully retract the cylinder.
  - a. Refer to (page 6) the Bleed Cycle Procedure Instructions to purge air from the hydraulic system.
15. If needed refill the reservoir to the "Full line" labeled on the side of the reservoir. Fluid level should be approximately 1 inch from the top of the reservoir.
16. After both cylinders are primed and fully retracted, recheck the level of the oil in the reservoir.

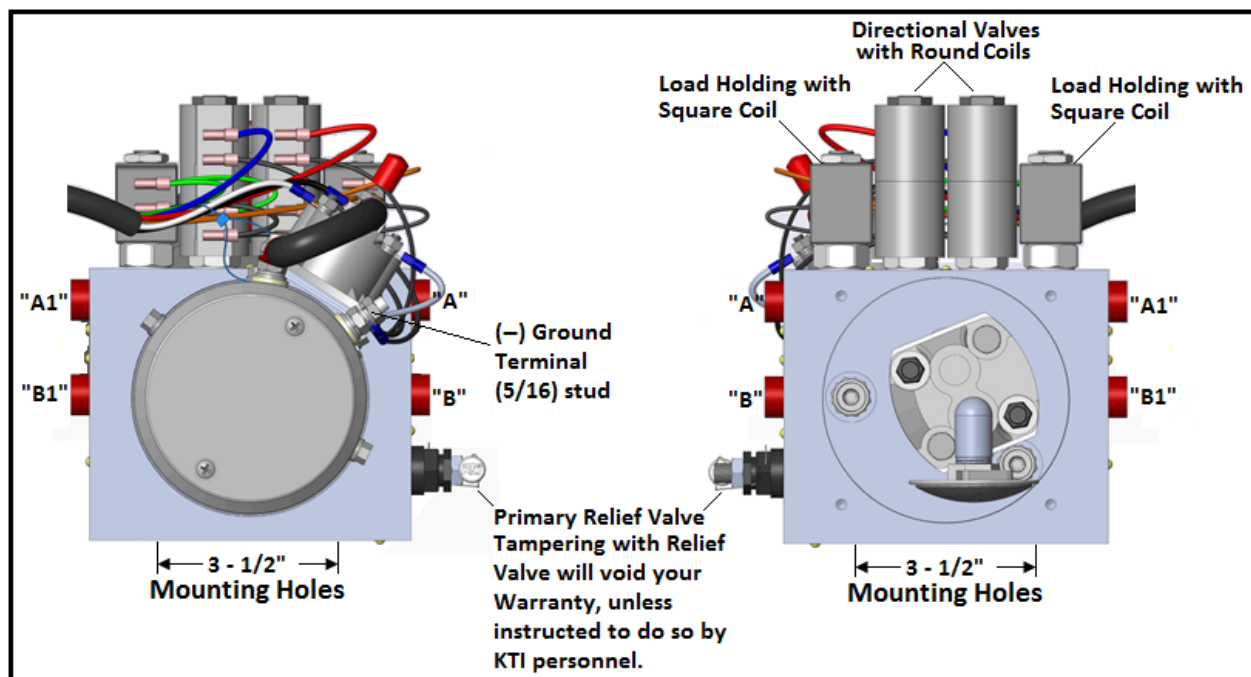

Diagram A-2



### Fluid Recommendations

#### Do Not Mix Hydraulic Fluids.

KTI recommends using a premium hydraulic oil to ensure optimum performance and system life. Select oil that has anti-wear properties, rust and oxidation inhibitors, foam inhibitors and good stability. Examples of premium grade hydraulic oils: **Chevron Rando HDZ**, **Mobil DTE 10**, **DTE 20 series**, **AMSOIL**, and **Shell Tellus**. Automotive Transmission Fluid (DEXRON III) are acceptable under normal conditions.

Aviation Oils such as **Valvoline ROYCO series** or **Mobil Aero HF** or **HFA** may be used in **prolonged, extreme cold** environments.

**Do Not Use Biodegradable Hydraulic Fluid with Buna seal, Biodegradable Hydraulic Fluid is compatible with Viton seals (optional).**

Ambient Temperature Range	ISO Viscosity Grade
- 20°F to + 32°F (- 29°C to + 0°C)	15
+ 14°F to + 120°F (- 10°C to + 49°C)	22, 32, ATF (Dexron III)

### Battery Cables

To minimize voltage drop, increase the gauge size of the battery cables as the length of the positive and ground cables increase. Low voltage will cause the motor to run higher amps causing damage to other electrical components.

Cable Length	Wire Gauge	Nominal OD (in.)
1 to 2 feet	4 gauge	0.43
3 to 4 feet	2 gauge	0.49
5 to 7 feet	1 gauge	0.56
8 to 9 feet	1/0 gauge	0.61
10 to 12 feet	2/0 gauge	0.66
13 to 15 feet	3/0 gauge	0.72
16 to 19 feet	4/0 gauge	0.78



### Hydraulic Schematic

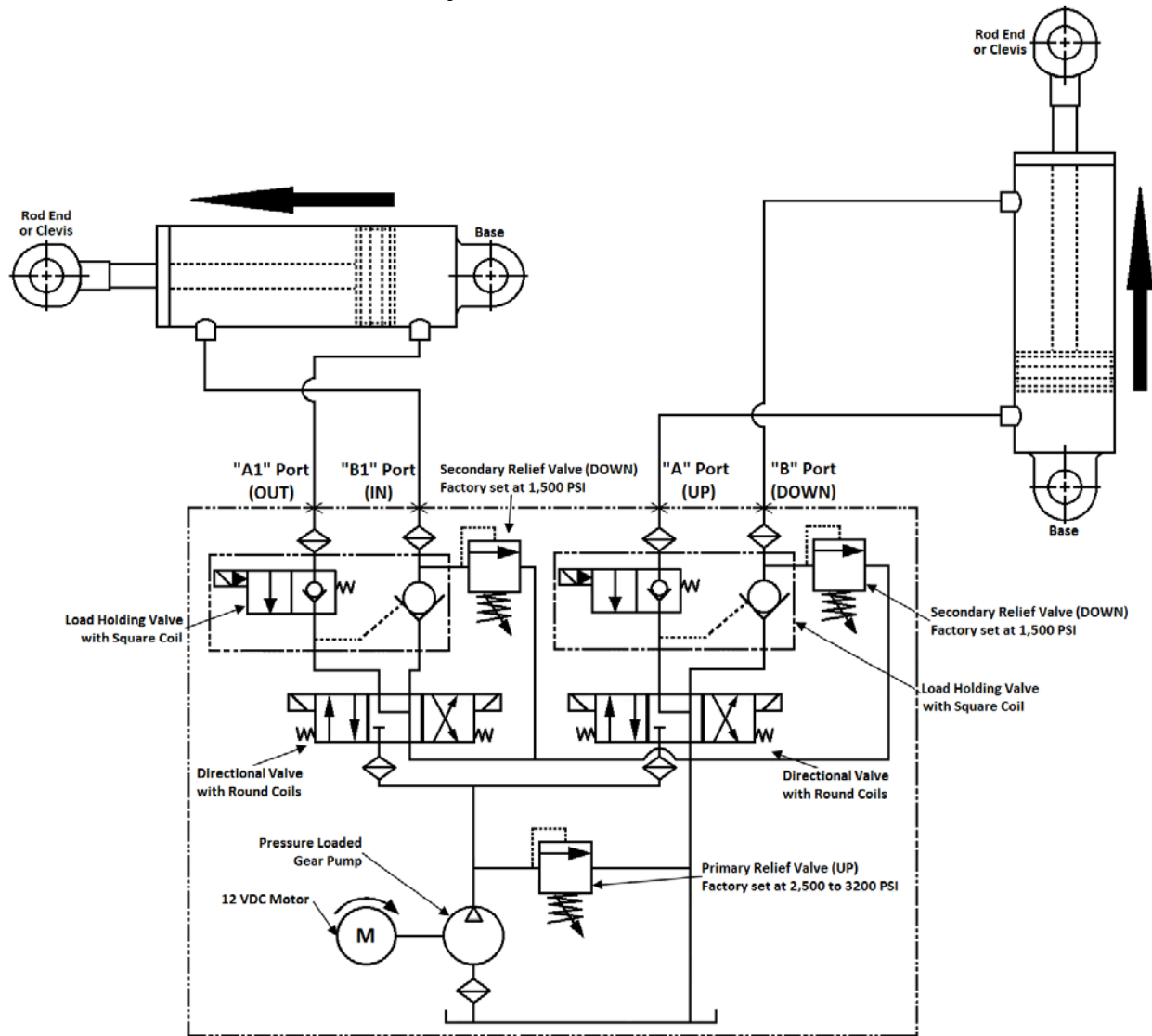

Diagram A-3



### Wiring Diagram

